

- Square & Short Type for Super Hardened Steel

EHS-□S

(SH Type) 超高硬

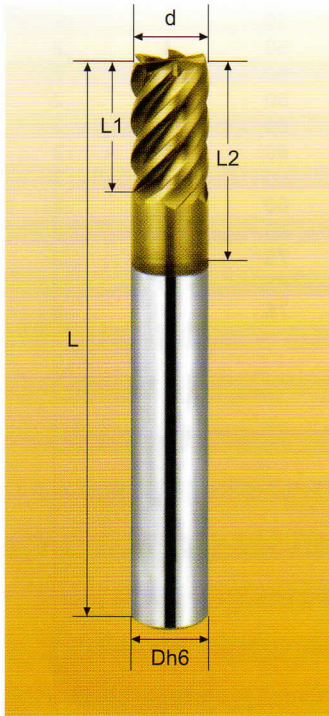

Order No. 訂購編號	Dia. 刃徑 (d)	CL 刃長 (L1)	EFF-L 有效長 (L2)	OAL 全長 (L)	Shank 柄徑 (D)	Flutes 刃數 (F)
EHSPS301000S	1	1.5	2.5	50	4	3
EHSPS402000S	2	3.0	5.0	50	4	4
EHSUS403000S	3	4.5	7.5	50	6	4
EHSUS404000S	4	6.0	10.0	50	6	4
EHSUS405000S	5	7.5	12.5	50	6	4
EHSUS606000S	6	9.0	15.0	50	6	6
EHSUS608000S	8	12.0	20.0	60	8	6
EHSUS610000S	10	15.0	25.0	75	10	6
EHSUS612000S	12	18.0	30.0	75	12	6
EHSUS816000S	16	24.0	40.0	100	16	8
EHSUS820000S	20	30.0	50.0	100	20	8

INCH SIZE

EHSUS403X00S	1/8	5/32	1/2	2-1/2	1/4	4
EHSUS404X00S	3/16	7/32	3/4	2-1/2	1/4	4
EHSUS606X00S	1/4	9/32	3/4	2-1/2	1/4	6
EHSUS607X00S	5/16	13/32	1	2-1/2	5/16	6
EHSUS609X00S	3/8	15/32	1	2-1/2	3/8	6
EHSUS612X00S	1/2	5/8	1-1/4	3	1/2	6
EHSUS815X00S	5/8	3/4	1-1/2	3-1/2	5/8	8
EHSUS819X00S	3/4	15/16	1-3/4	4	3/4	8

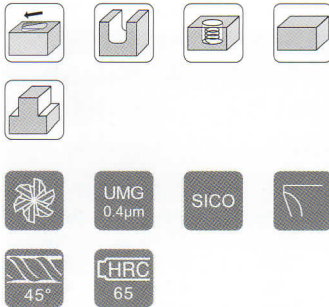

d	Tolerance
$\varnothing \leq 12$	0 ~ -0.02
$\varnothing > 12$	0 ~ -0.03

WORKING MATERIAL	HARDENED STEEL		HARDENED STEEL		HARDENED STEEL	
MATERIAL CODE	SKT,SKD		SKT,SKD		SKT,SKD	
HARDNESS GRADE	HRC 45-55		HRC 55-60		HRC 60-70	
Vc	160 M / min		150 M / min		99 M / min	
DIAMETER	R.P.M	FEED (mm / min)	R.P.M	FEED (mm / min)	R.P.M	FEED (mm / min)
6MM	8,500	2,450	7,950	2,000	5,300	1,210
8MM	6,350	2,440	5,950	1,995	4,000	1,215
10MM	5,100	2,450	4,700	1,970	3,200	1,215
12MM	4,250	2,450	3,950	1,985	2,650	1,210
14MM	3,600	2,420	3,400	1,995	2,250	1,200
16MM	3,150	2,420	3,000	2,000	1,950	1,285
18MM	2,800	2,420	2,650	2,000	1,750	1,200
20MM	2,500	2,400	2,350	1,970	1,550	1,180
25MM	2,000	2,400	1,900	1,990	1,250	1,190

Finishing (精銑)	◎
Semi-Finishing (中銑)	◎
Roughing (粗銑)	○

Milling Amount (mm)

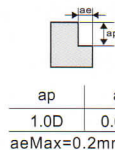

ap	ae	ap	ae	ap	ae
1.0D	0.02D	1.0D	0.01D	1.0D	0.01D
aeMax=0.2mm以下					

The Feed & RPM may be changed depending on the M/C Conditions, Lubricating & Cooling systems.