

MICRO GRAIN CARBIDE HIGH PERFORMANCE DRILLS - Endmill Shank

With Coolant Hole - 2F(3xD) 高效能內冷鑽頭-短刃型-3xD (銑刀柄)

**DST-CA2**

**DST-HA2**

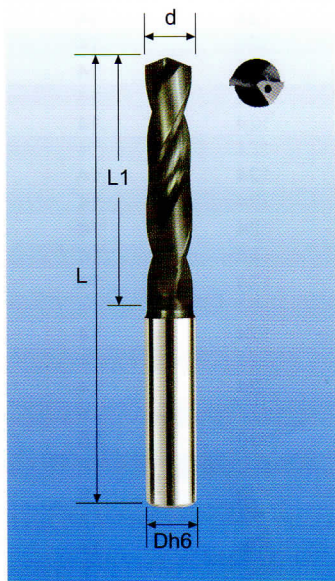

CUTTING EFFECTED LENGTH = 3xD

**Dimension**

- Sim. DIN6537
- 140 Degree Tip Angle
- 25~35 Degree Helix Angle
- With Coolant Hole
- AlTiN Coating

**Tolerance**

- d h7
- D h6

**Material**

- ALLOY STEELS
- STAINLESS STEELS
- CAST IRON
- TITANIUM STEELS

**Recommend**

**Cutting Condition**

Table 2

Order No. 訂購編號	Dia. 刃徑 (d)	CL 刃長 (L1)	OAL 全長 (L)	Shank 柄徑 (D)
DSTCA202006T	2.00	20	50	3
DSTCA203006T	3.00	20	50	4
DSTCA203106T	3.10	20	50	4
DSTCA203176T	3.175	20	50	4
DSTCA203206T	3.20	20	50	4
DSTCA203256T	3.25	20	50	4
DSTCA203306T	3.30	20	50	4
DSTCA203406T	3.40	20	50	4
DSTCA203506T	3.50	20	50	4
DSTCA203606T	3.60	20	50	4
DSTCA203706T	3.70	20	50	4
DSTCA203806T	3.80	24	60	4
DSTCA203906T	3.90	24	60	4
DSTCA203976T	3.97	24	60	4
DSTCA204006T	4.00	24	60	4
DSTHA204106T	4.10	24	65	6
DSTHA204206T	4.20	24	65	6
DSTHA204306T	4.30	24	65	6
DSTHA204406T	4.40	24	65	6
DSTHA204506T	4.50	24	65	6
DSTHA204606T	4.60	24	65	6
DSTHA204656T	4.65	24	65	6
DSTHA204706T	4.70	24	65	6
DSTHA204806T	4.80	28	65	6
DSTHA204906T	4.90	28	65	6
DSTHA205006T	5.00	28	65	6
DSTHA205106T	5.10	28	65	6
DSTHA205206T	5.20	28	65	6
DSTHA205306T	5.30	28	65	6
DSTHA205406T	5.40	28	65	6
DSTHA205506T	5.50	28	65	6
DSTHA205566T	5.56	28	65	6
DSTHA205606T	5.60	28	65	6
DSTHA205706T	5.70	28	65	6
DSTHA205806T	5.80	28	65	6
DSTHA205906T	5.90	28	65	6
DSTHA206006T	6.00	28	65	6
DSTHA206106T	6.10	34	79	8
DSTHA206206T	6.20	34	79	8
DSTHA206306T	6.30	34	79	8
DSTHA206356T	6.35	34	79	8
DSTHA206406T	6.40	34	79	8
DSTHA206506T	6.50	34	79	8
DSTHA206606T	6.60	34	79	8
DSTHA206706T	6.70	34	79	8

MICRO GRAIN CARBIDE HIGH PERFORMANCE DRILLS - Endmill Shank

With Coolant Hole - 2F(3xD) 高效能內冷鑽頭-短刃型-3xD (銑刀柄)

**DST-CA2**

**DST-HA2**

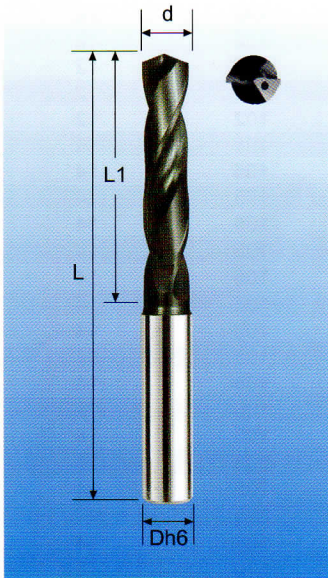

CUTTING EFFECTED LENGTH = 3xD

**Dimension**

- Sim. DIN6537
- 140 Degree Tip Angle
- 25~35 Degree Helix Angle
- With Coolant Hole
- AlTiN Coating

**Tolerance**

- d h7
- D h6

**Material**

- ALLOY STEELS
- STAINLESS STEELS
- CAST IRON
- TITANIUM STEELS

**Recommend**

**Cutting Condition**

Table 2

Order No. 訂購編號	Dia. 刃徑 (d)	CL 刃長 (L1)	OAL 全長 (L)	Shank 柄徑 (D)
DSTHA206806T	6.80	34	79	8
DSTHA206906T	6.90	34	79	8
DSTHA207006T	7.00	34	79	8
DSTHA207106T	7.10	41	79	8
DSTHA207206T	7.20	41	79	8
DSTHA207306T	7.30	41	79	8
DSTHA207406T	7.40	41	79	8
DSTHA207506T	7.50	41	79	8
DSTHA207606T	7.60	41	79	8
DSTHA207706T	7.70	41	79	8
DSTHA207806T	7.80	41	79	8
DSTHA207906T	7.90	41	79	8
DSTHA208006T	8.00	41	79	8
DSTHA208106T	8.10	47	89	10
DSTHA208206T	8.20	47	89	10
DSTHA208306T	8.30	47	89	10
DSTHA208406T	8.40	47	89	10
DSTHA208506T	8.50	47	89	10
DSTHA208606T	8.60	47	89	10
DSTHA208706T	8.70	47	89	10
DSTHA208806T	8.80	47	89	10
DSTHA208906T	8.90	47	89	10
DSTHA209006T	9.00	47	89	10
DSTHA209106T	9.10	47	89	10
DSTHA209206T	9.20	47	89	10
DSTHA209256T	9.25	47	89	10
DSTHA209306T	9.30	47	89	10
DSTHA209406T	9.40	47	89	10
DSTHA209506T	9.50	47	89	10
DSTHA209606T	9.60	47	89	10
DSTHA209706T	9.70	47	89	10
DSTHA209806T	9.80	47	89	10
DSTHA209906T	9.90	47	89	10
DSTHA210006T	10.00	47	89	10
DSTHA210106T	10.10	55	102	12
DSTHA210206T	10.20	55	102	12
DSTHA210306T	10.30	55	102	12
DSTHA210406T	10.40	55	102	12
DSTHA210506T	10.50	55	102	12
DSTHA210606T	10.60	55	102	12
DSTHA210706T	10.70	55	102	12
DSTHA210806T	10.80	55	102	12
DSTHA210906T	10.90	55	102	12
DSTHA211006T	11.00	55	102	12
DSTHA211106T	11.10	55	102	12

MICRO GRAIN CARBIDE HIGH PERFORMANCE DRILLS - Endmill Shank

With Coolant Hole - 2F(3xD) 高效能內冷鑽頭-短刃型-3xD (銑刀柄)

**DST-CA2**  
**DST-HA2**

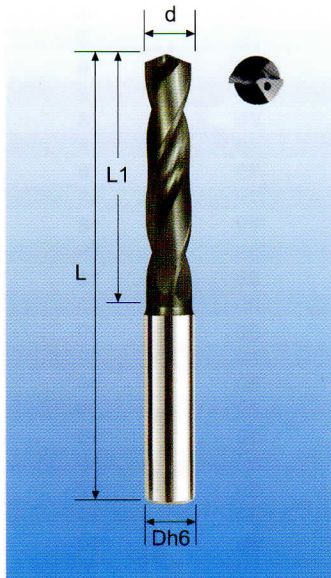

CUTTING EFFECTED LENGTH = 3xD

**Dimension**

- Sim. DIN6537
- 140 Degree Tip Angle
- 25~35 Degree Helix Angle
- With Coolant Hole
- AlTiN Coating

**Tolerance**

- d h7
- D h6

**Material**

- ALLOY STEELS
- STAINLESS STEELS
- CAST IRON
- TITANIUM STEELS

**Recommend**

**Cutting Condition**

Table 2

Order No. 訂購編號	Dia. 刃徑 (d)	CL 刃長 (L1)	OAL 全長 (L)	Shank 柄徑 (D)
DSTHA211206T	11.20	55	102	12
DSTHA211306T	11.30	55	102	12
DSTHA211406T	11.40	55	102	12
DSTHA211506T	11.50	55	102	12
DSTHA211606T	11.60	55	102	12
DSTHA211706T	11.70	55	102	12
DSTHA211806T	11.80	55	102	12
DSTHA211906T	11.90	55	102	12
DSTHA212006T	12.00	55	102	12
DSTHA212106T	12.10	60	105	14
DSTHA212206T	12.20	60	105	14
DSTHA212306T	12.30	60	105	14
DSTHA212406T	12.40	60	105	14
DSTHA212506T	12.50	60	105	14
DSTHA212606T	12.60	60	105	14
DSTHA212706T	12.70	60	105	14
DSTHA212806T	12.80	60	105	14
DSTHA212906T	12.90	60	105	14
DSTHA213006T	13.00	60	105	14
DSTHA213206T	13.20	60	105	14
DSTHA213306T	13.30	60	105	14
DSTHA213506T	13.50	60	105	14
DSTHA213706T	13.70	60	105	14
DSTHA213806T	13.80	60	105	14
DSTHA214006T	14.00	60	105	14
DSTHA214206T	14.20	65	110	16
DSTHA214306T	14.30	65	110	16
DSTHA214406T	14.40	65	110	16
DSTHA214506T	14.50	65	110	16
DSTHA214706T	14.70	65	110	16
DSTHA215006T	15.00	65	110	16
DSTHA215206T	15.20	65	110	16
DSTHA215506T	15.50	65	110	16
DSTHA215606T	15.60	65	110	16
DSTHA215706T	15.70	65	110	16
DSTHA215806T	15.80	65	110	16
DSTHA216006T	16.00	65	110	16
DSTHA216506T	16.50	73	123	18
DSTHA217006T	17.00	73	123	18
DSTHA217506T	17.50	73	123	18
DSTHA218006T	18.00	73	123	18
DSTHA218506T	18.50	79	130	20
DSTHA219006T	19.00	79	130	20
DSTHA219506T	19.50	79	130	20
DSTHA220006T	20.00	79	130	20